

4

3

DWG NO 2201A006

SHEET 1

REV 0

1

NEXT ASSEMBLY

REVISION HISTORY

REV	DESCRIPTION	ECN	DATE	BY	APPROVED
		-			

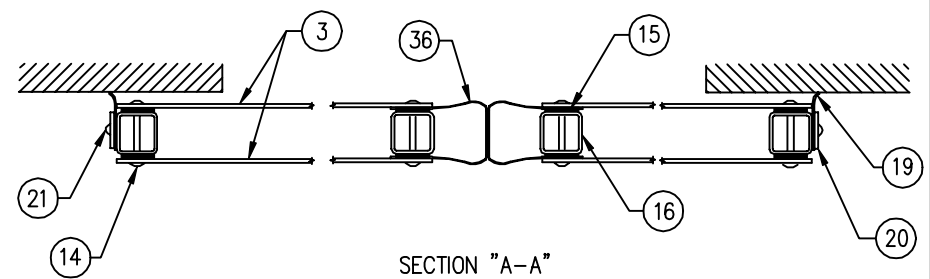
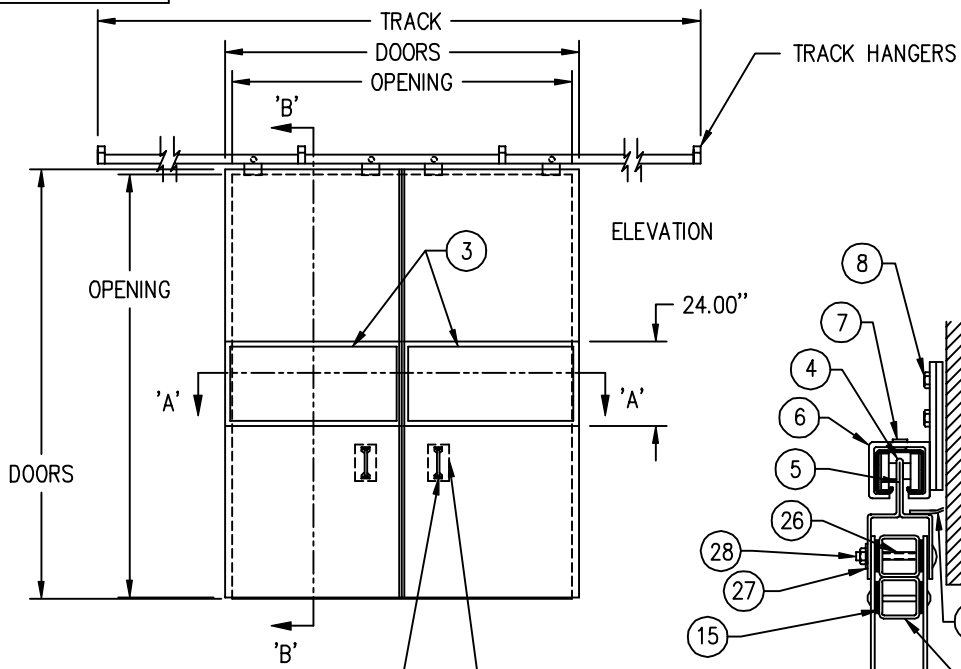

COLOR: TO BE SELECTED.

ITEM	QTY	PART NO.	DWG. NO.	DESCRIPTION
28	-	-	-	TROLLEY MOUNTING NUT
27	-	-	-	TROLLEY MOUNTING LOCK WASHER
26	-	-	-	TROLLEY MOUNTING BOLT
21	-	-	-	AIR SEAL MOUNTING SCREW
20	-	-	-	AIR SEAL MOUNTING STRIP
19	-	-	-	SIDE AIR SEAL
16	-	-	-	1 1/4" SQUARE STEEL TUBING
15	-	-	-	CLOSED CELL TAPE
14	-	-	-	RIVETS
13	-	-	-	HEADER AIR SEAL
12	-	-	-	FLOOR AIR SEAL
10	-	-	-	FLOOR GUIDE TRACK
9	-	-	-	FLOOR ROLLER GUIDE
8	-	-	-	HEX HEAD MOUNTING BOLT
7	-	-	-	TRACK HANGER SET SCREW
6	-	-	-	TRACK HANGER
5	-	-	-	TROLLEY
4	-	-	-	TRACK - 12 GA
3	-	-	-	1/8" THICK POLYCARBONATE VISION PANELS
2	-	-	-	POLYSTYRENE INSULATING CORE
1	-	-	-	DOOR FACING - 1/8" THICK ABS

SURFACE MOUNT HANDLE THIS SIDE.

RECESS MOUNT HANDLE REVERSE SIDE.

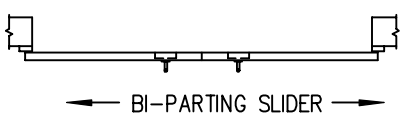

PLAN

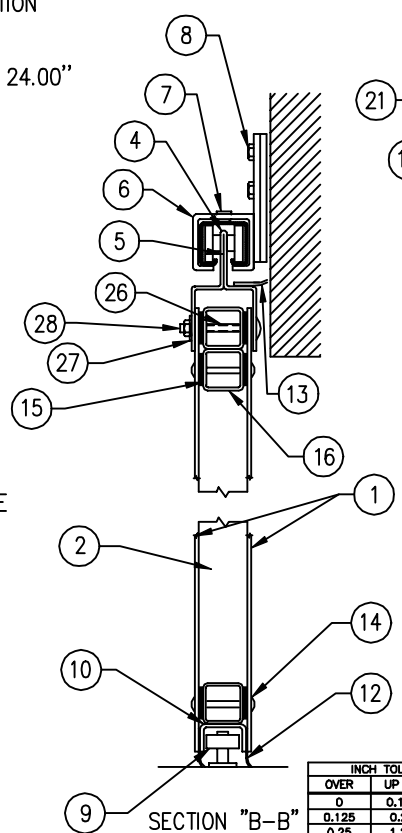

SECTION "B-B"

INCH TOLERANCES			DO NOT SCALE DRAWING	
OVER	UP TO	+ / -	MM-DD-YY	DATE
0	0.125	0.005	JTD	02/15/1999
0.125	0.25	0.010		
0.25	1.25	0.020		
1.25	5	0.030		
5	15	0.040		
15	40	0.060		
40	80	0.100		
80	-	0.125		

**RITE-HITE**  
DOORS INC.

TITLE  
ARCHITECTURAL APPROVAL  
4800, SLIDER, PAIR

SIZE B	MODEL NUMBER 4800	DWG NO 2201A006	REV -
SCALE 1/4" = 1'		PART #	SHEET 1

4

3

2

1